

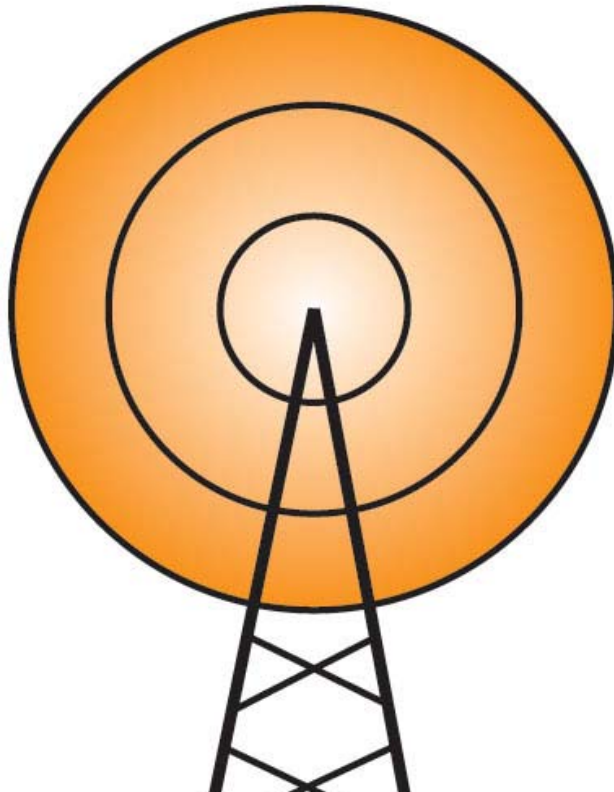

ARRIS

System Description



**850MHz
BROADBAND
WIRELESS**



February 2005

Table of Contents

1 Executive Summary	1
2 System Overview	1
2.1 DOCSIS® Overview.....	2
2.1.1 Physical Layer Characteristics	2
2.1.2 Media Access Control (MAC).....	3
2.1.3 Security.....	3
2.2 Point to Multipoint Configuration	3
2.2.1 Base Station	6
2.2.2 Subscriber	8
2.3 Element and Network Management.....	10
3 Ongoing Field Trial	10
4 Contact Information	10

1 Executive Summary

ARRIS is pleased to present you with this summary description of a typical Broadband Wireless Access network solution based on proven Data over Cable Service Interface Specifications (DOCSIS®) technology.

Our network solution proposal marries DOCSIS® Cable Modem Termination Systems (CMTS) with ARRIS radio frequency (RF) technology. Commercial deployments have demonstrated that the CMTS approach achieves high performance and reliability in a cost-effective fashion.

ARRIS designs and supplies leading-edge broadband access transmission equipment, primarily for broadband fixed wireless networks and data over cable. Service providers use ARRIS's products to deliver high-speed data, Internet, video on demand (VOD), Voice over IP (VoIP), and other bandwidth-intensive services to residential and business subscribers. ARRIS's products are designed to allow service providers to rapidly and cost-effectively bridge the last mile, by overcoming the bottleneck resulting from insufficient bandwidth existing in legacy last mile infrastructures. The Company's customer base includes original equipment manufacturers (OEM), system integrators, leading multiple system operators (MSO) and other service providers. Please find details at www.arrisi.com/.

A key benefit of ARRIS's solution is that high volumes of standard DOCSIS® modems are being produced by a large number of manufacturers; the economies of scale thus created result in inexpensive, feature-rich subscriber equipment.

The basic, most cost-effective network is designed with only a limited amount of redundancy. Options are available that provide full 1-to-1 redundancy for all CMTS and base station RF equipment.

2 System Overview

The architecture of the system uses standard DOCSIS® cable equipment as the network elements. Complementing this standard DOCSIS® setup is ARRIS-sourced RF hardware designed to translate specific sub-bands of the DOCSIS® cable frequency plan into the frequency allocations of each specific customer.

Key characteristics of the system are:

- 8.6 Mbps time division multiplexed downstream using 64QAM in a 2 MHz channel
- 256 Kbps to 10 Mbps time division multiple access (TDMA) burst per upstream using QPSK, QAM8, or QAM16 modulations in 200kHz to 3.2 MHz bandwidths

- near line of sight performance
- other systems already operating at 600 MHz, 700MHz, 1.9 GHz, 2.1 GHz, 2.3 GHz, 2.5 GHz , 3.5 GHz and 5.7 GHz around the world
- audible installation alignment beeper available on some models to facilitate customer self-install and avoid a truck roll
- economies of scale by reusing existing DOCSIS® products which are now being deployed in high volume worldwide

2.1 DOCSIS® Overview

DOCSIS® is an open industry standard developed and coordinated through the efforts of cable MSOs and technology manufacturers such as ARRIS. Under the watch of the non-profit institution CableLabs®, DOCSIS® technology is mature and in operation in many countries around the world as the standard for Internet access on hybrid fiber coax cable systems. A fundamental advantage of using DOCSIS® is the wide variety of manufacturers producing cable modems and the volumes currently being deployed which translate into very cost-effective subscriber equipment. Over 15 million DOCSIS® cable modems are currently deployed worldwide with over 200,000 upstream DOCSIS® ports.

DOCSIS® wireless-based cable modem pricing is now less than US\$65 when purchased in quantity.

The technology behind DOCSIS® also lends itself very well to use as a fixed broadband wireless access mechanism. A well-developed physical layer, sophisticated media access control, and a complete network reference model provide for a commercial grade wireless system.

A quick overview of features is given below, but a more thorough discussion on the specific technical requirements for wireless can be provided as your project matures. The CableLabs® website, www.cablemodem.com/ also contains the current DOCSIS® specifications.

2.1.1 Physical Layer Characteristics

Key parameters of the physical layer include:

Downstream:

- 8.6 Mbps in a 2 MHz RF channel (Optional 27Mbps in 6 MHz)
- 64QAM and 16 QAM modulations
- Reed-Solomon forward error correction (~10% overhead)

- continuous transmission

Upstream:

- variable channel bandwidths from 200 KHz to 3.2 MHz
- QPSK, 8QAM, and 16QAM modulations
- Reed-Solomon forward error correction (~10% overhead)
- burst mode transmission
- error correction
- signal precompensation
- adaptive power control over 50 dB range
- encryption

2.1.2 Media Access Control (MAC)

The DOCSIS® MAC uses a request/grant mechanism under central management of the CMTS. This time division multiple access (TDMA) reservation-based protocol requires each CPE to request a time to transmit data. The CMTS examines all of the incoming requests and grants a time to transmit based on a multitude of parameters including CPE data rate limitations and service priorities. A DOCSIS® compliant system with full QoS features is standard.

2.1.3 Security

Baseline Privacy Plus (BPI+), included as part of the DOCSIS® protocol, provides advanced security and privacy features for both the service provider and the customer. All over-the-air communications operate with 56-bit DES encryption (or 40-bit where regulations require).

Additionally, encrypted key management between the CMTS and modems requires subscriber authorization and registration to ensure reliable and secure billing for multiple server classes, which prevents unauthorized access to the system. CMTSs and cable modems can support end-to-end 3DES encryption.

2.2 Point to Multipoint Configuration

Figure 1 shows the overall system diagram for a simple omnidirectional point to multipoint communication system. In this drawing, a single downstream and upstream antenna is shown. Many combinations of antennas and sectorization can be deployed.

This capability at 850 MHz requires three additional ARRIS-supplied components to complement the CMTS at the base station site. These additional components serve to convert the standard DOCSIS® cable frequency plan to the required 850 MHz frequency plan and include the following:

- UCD4940-1 Wireless Interface (Indoor Unit)
- PA850 Power Amplifier (Indoor Unit)
- Rx and Tx Filter Assemblies

This UCD4940-1 module provides the following interfaces:

Network Element	Interfaces
CMTS	Upstream IF at 17-42 MHz Downstream from 869Mhz to 894Mhz Downstream IF at 44 MHz (single channel per module on female 'F' connector)
NMS Power Amp	RS-232/485 terminal port Future optional SNMP over 10BaseT Ethernet Downstream RF 470 to 860 MHz band
Other	Front panel display and controls AC (100-240VAC) or DC (-48VDC) power supply connection

Detailed network capacity and RF planning is necessary to determine the optimum solution for a specific customer requirement. ARRIS can support systems operating in the US cellular A and B as defined by the FCC:

Block A Downstream: 869 to 880 MHz
Block A Upstream: 824 to 835 MHz

Block B Downstream: 880 to 890 MHz
Block B Upstream: 835 to 845 MHz

Detailed network capacity and RF planning is necessary to determine the optimum solution for a specific customer requirement. ARRIS can also provide custom frequencies from 470 to 900 MHz. Custom spacing and subbands for specific customer and country frequency allocations can be developed as required.

To gain additional frequency reuse with the limited available bandwidth at 850MHz, ARRIS has also created a variation of its standard wireless modem. The WM450-2 variation only requires a 2MHz channel of operation thus allowing a frequency reuse of three to be obtained. This model, depending on the application, can still deliver up to 8.6Mbps per base station downstream or sector. In certain tower locations, it is possible to use the standard 6MHz WM450 modem.

FIGURE 1 - POINT TO MULTIPOINT SYSTEM OVERVIEW

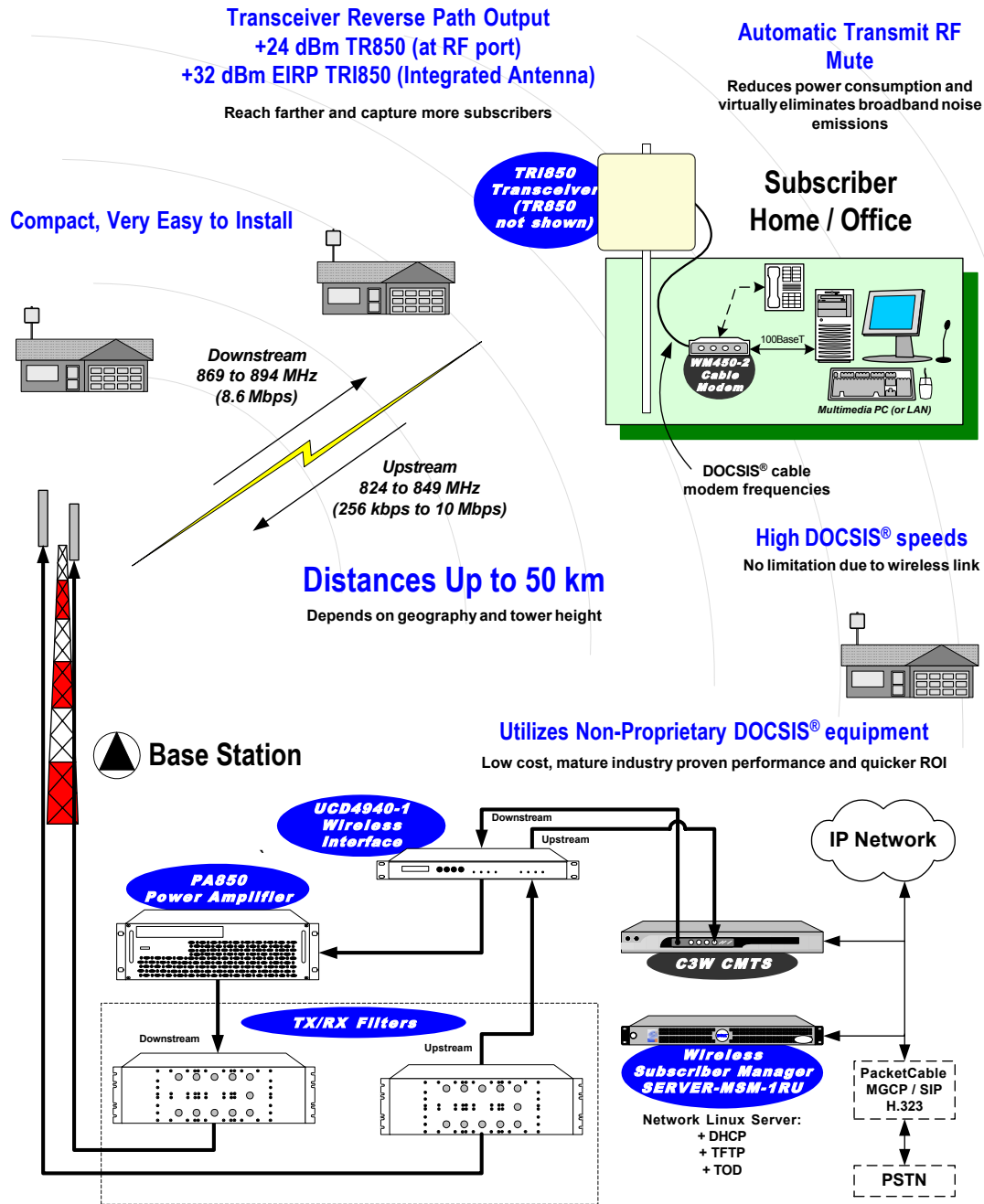

Figure 1: Point-to-Multipoint Overview

2.2.1 Base Station

Figure 2 shows a detailed diagram of a more elaborate base station configuration. In this application, a single downstream transmit is used along with three separate upstream receive sectors each offset by 120 degrees. This application, with the higher gain receives

antennas, helps to maximize the total distance covered. Additional components from the 850MHz family of equipment have been used to create this configuration.

FIGURE 2 - POINT TO MULTIPOINT BASE STATION DETAIL
Omnidirectional Downstream & 4 Sector Upstream

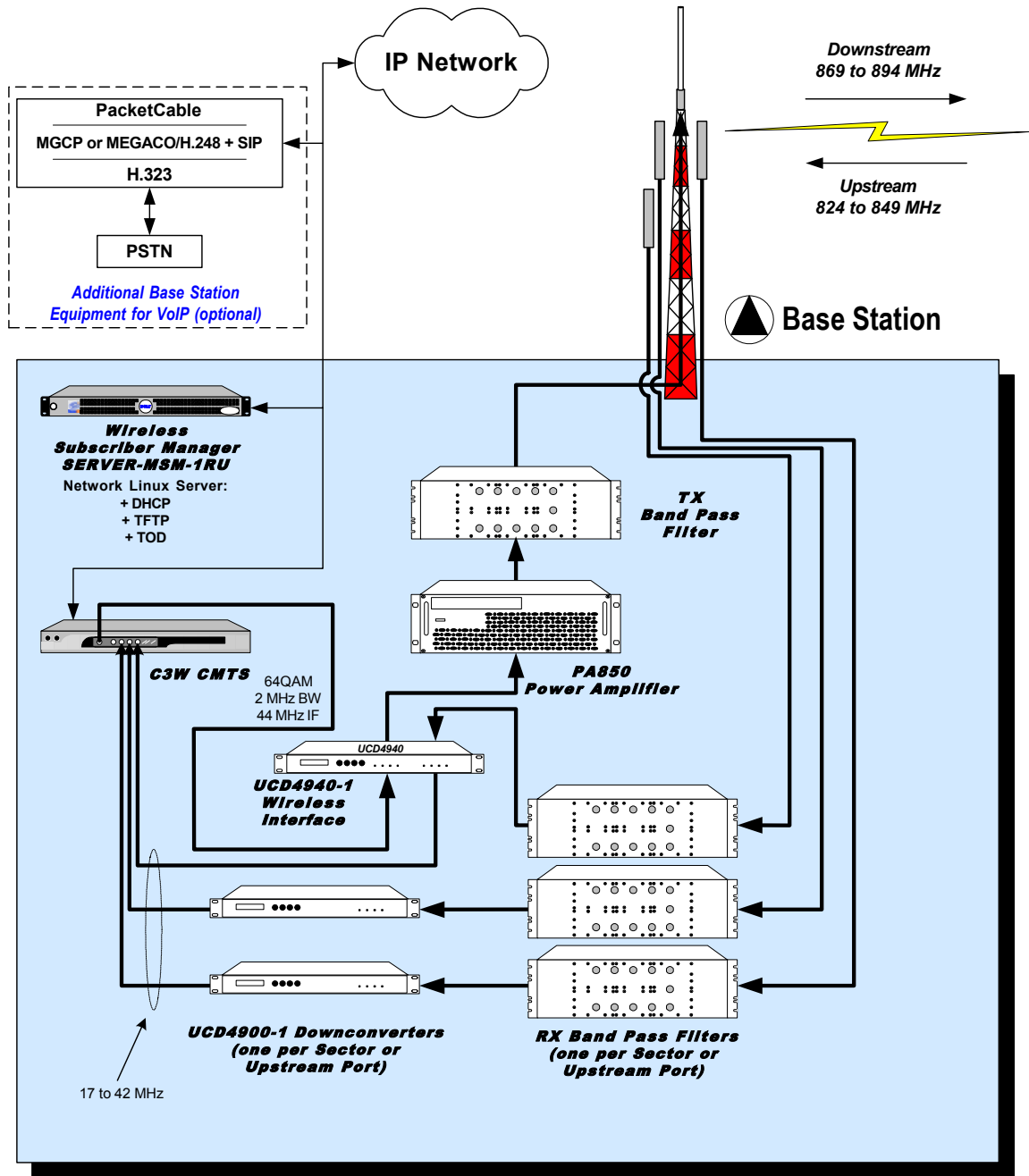

Figure 2: Sectored Upstream Base Station Detail

2.2.2 Subscriber

Figure 3 details the configuration for a standard subscriber installation. There are two fundamental elements, each with multiple options depending on performance and feature set: the outdoor RF transceiver (TRI850) and the indoor DOCSIS® WM450-2 modem.

The TR850I Subscriber Transceiver serves to translate frequencies and amplify the upstream and downstream signals to the appropriate cable frequencies for use by the indoor DOCSIS® modem. A highly directional flat panel antenna is integrated with the transceiver, and a single low-cost 75 ohm coaxial cable (that is, RG-59 or RG-6) is used to connect between the transceiver IF port and indoor AC/DC power inserter. A short coaxial jumper cable is used to connect from the power inserter to the DOCSIS® modem. The DOCSIS® cable modem serves to provide two-way broadband Internet access to the local PCs or LAN via either an Ethernet or USB connection.

If voice service (VoIP) is also desired, the ARRIS WM402-2 voice and data unit can be substituted for the WM450-2 modem.

FIGURE 3 - POINT TO MULTIPOINT SUBSCRIBER DETAIL Subscriber Home/Office

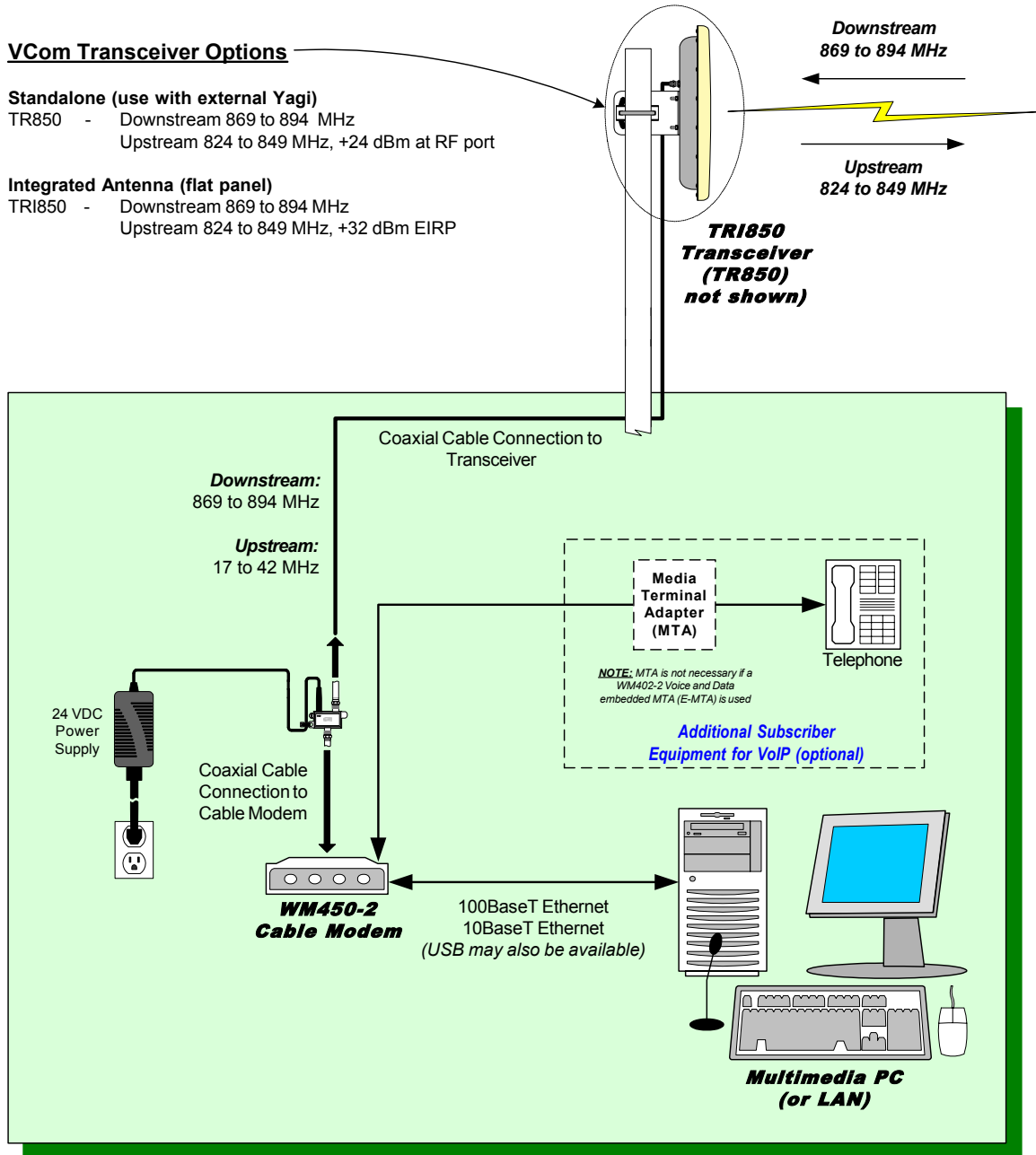

Figure 3: Point-to-Multipoint Subscriber Home/Office Detail

2.3 Element and Network Management

For smaller systems, all network and RF elements, with the exception of the subscriber RF transceivers, are fully visible on the network when using the PC Server. This unit is a Linux-based Web server configured with the Microwave History Manager (MHM) software. The MHM software offers basic logging and display of cable modem performance and usage statistics.

The optional Microwave Subscriber Manager (MSM) software offers DHCP, TFTP, customer database, individual control of cable modems, and latitude/longitude mapping support functions in addition to the basic functions available in MHM.

For larger scale systems and those requiring VoIP services, ARRIS's ALOPA subscriber management system provides all of the features required to maintain and control large numbers of subscribers. It can also be used to directly interface many of the customer billing systems available.

3 Ongoing Field Trial

ARRIS can now supply 33 different transceiver designs covering frequency bands from 500 MHz to 6 GHz.

References to customers with operational systems on four continents are available on request.

ARRIS would be pleased to demonstrate this system and to put in place any particular tests or equipment configurations to demonstrate the performance and manageability of the system.

4 Contact Information

For more information contact:

[ARRIS International](#)

[800-469-6569 \(in the U.S.\)](#)

[e-mail: wireless@arrisi.com](mailto:wireless@arrisi.com)

www.arriswireless.com

www.arrisi.com

From North America, call toll-free: 800-469-6569. Outside North America: +1-678-473-2000. All contents are Copyright© 2004 ARRIS International, Inc. All rights reserved.

The DOCSIS® acronym belongs to CableLabs®

DOCSIS® is a registered trademark