



## C-COR® Flex Max901e

### 1 GHz Bridger Amplifiers



The ARRIS C-COR Flex Max901e 1 GHz Bridger Amplifiers are the new industry standard for RF distribution products. 1 GHz will enable broadband service providers to increase forward capacity for HDTV over previous program offerings, typically allowing a 40% increase over current HDTV channels in a lineup.

The high forward gain and output configurations provided by Flex Max901e Bridger Amplifiers are designed to overcome the higher insertion losses of coaxial cable and passives, and to ensure cost-effective new designs and drop-in upgrades of existing 750 and 870 MHz systems.

Flex Max901e Bridger Amplifiers are available as complete units for deploying new system builds, and, as drop-in RF modules for a 1 GHz upgrade of legacy 750MHz and 870MHz FlexNet bridger amplifiers. In addition, they can be used as spares in existing 750MHz and 870MHz systems. Operating specifications, such as gain and tilt, are maintained at 750MHz and 870MHz, with extended gain and tilt out to 1002MHz. These unique design considerations enable reuse of legacy amplifier housings and existing spacing, which in turn eliminates the cost of respicing, making the Flex Max901e drop-in RF module an economical choice for system upgrades up to 1 GHz.

#### Features

- 1 GHz technology
- -20 dB and -25 dB internal or external testpoints
- Expanded ALC pilot selection to match existing system designs
- Accepts all legacy 750 and 870 MHz equalizer and cable simulator plug-in accessories
- Supports major EMS protocols
- Plug-in diplex filters for future frequency split upgrades (bench upgrade only)
- Accessory insertion guides ease installation
- Optional 90° access ports for cost effectiveness in underground installations

- Operational specifications designed to enable legacy system upgrades without the need for respicing existing amplifier housings
- Factory aligned to 1 GHz specifications, but can be deployed into 750/870 MHz applications with field accessible plug-ins

## Functional Block Diagram

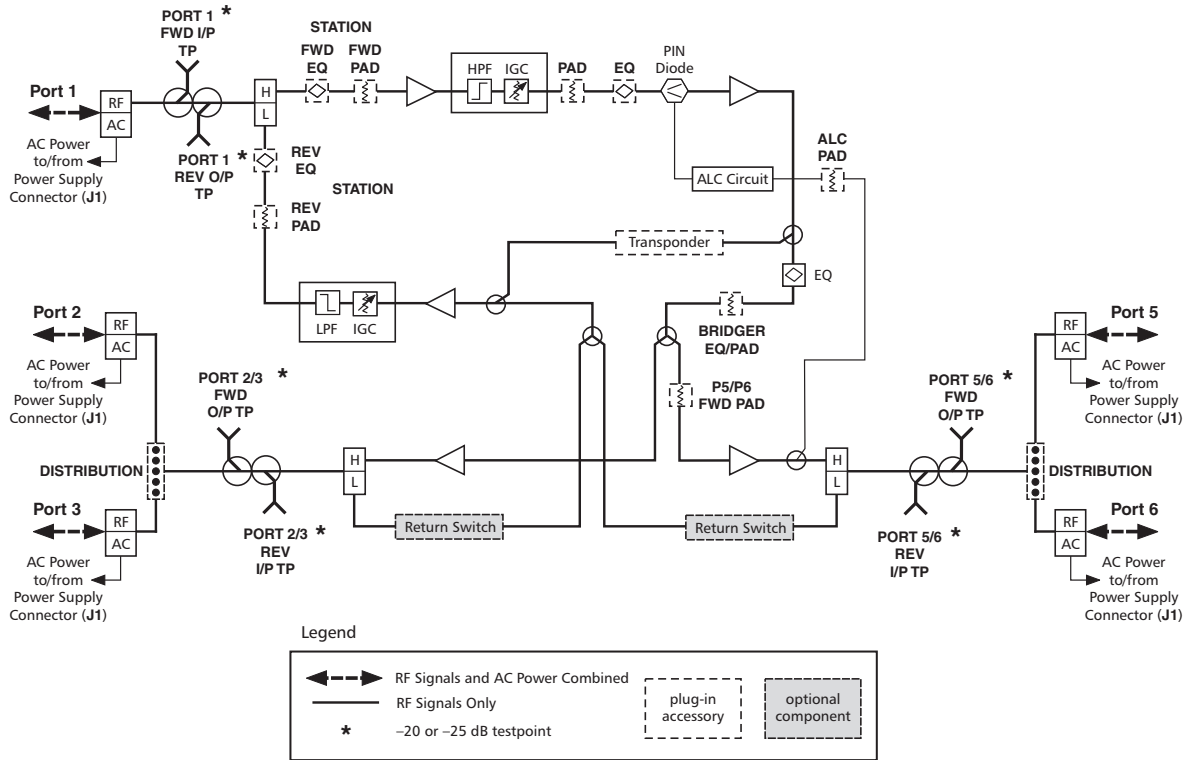

## Flex Max901e Bridger Amplifier

### Application

The Flex Max901e Trunk is a three active output station that provides one trunk level output and two distribution level outputs. The two active distribution or bridger ports can be configured in the field to provide four outputs. Flex Max901e Trunks provide a high performance trunk level output to "express" to other Trunks in the cascade for maximum distortion performance.

The **Flex Max901e Bridger** is used at the end of the express line. The Flex Max901e Bridger provides two high-level distribution outputs, which can also be configured in the field to provide four outputs. These distribution ports can be independently configured for specific applications.

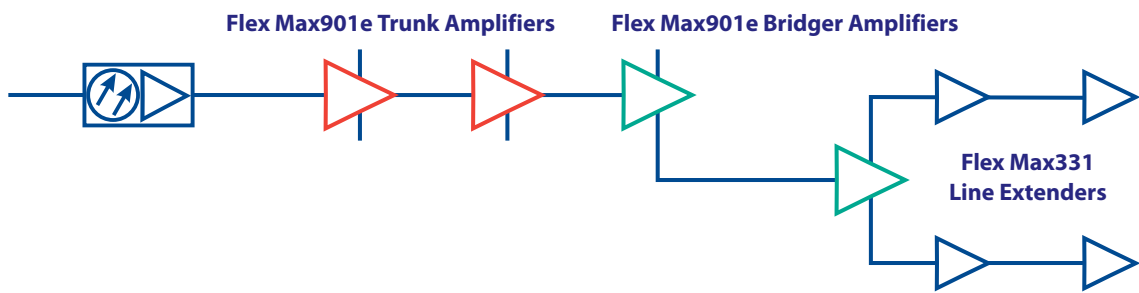

## Flex Max901e Bridger Amplifier Sample Specifications

	Forward Bridger (ea)	Return Bridger (ea)
<b>General</b>		
Passband, MHz	54–1002	5–42
Housing, MHz	1002	—
AC Current Passing, A—Ports 1, 3, 6	15	15
AC Current Passing, A—Ports 2, 5	13	13
<b>Typical Operating Conditions</b>		
Operational Gain, dB (–0, +0.5) (Note 1,2)	43	18
Channels, Number of NTSC (Note 3)	79	6
Operating Levels (recommended)		
Frequency, MHz	1002/870/750/550/54	42/5
Input, dBmV, min. (Note 4)	9.0/8.1/7.8/7.4/10.1	17/17
Output, dBmV (Notes 5 and 6)	52/49.5/47.5/44/35	35/35
<b>Performance Specifications @ Recommended Levels</b>		
Temperature Range: –40 to 60°C		
Carrier-to-Interference Ratio, dB (Note 7)		
Composite Triple Beat	75	80
Second Order Beat (F1 ± F2)	—	—
Cross Modulation (per NCTA std.) (Note 8)	67	74
Third Order Beat (F1 ± F2 ± F3)	—	—
Composite 2IM	73	82
Composite Intermodulation Noise CIN (Note 9)	73	—
Composite Intermodulation Noise CIN (Note 10)	79	—
Noise, 4MHz, 75Ohms (Note 2)	59/58.1/57.8/58.4/59.1	64
Noise Figure, dB (without EQ) (Note 11)	8/8/8/7/9	12
<b>Full Gain, dB (without EQ and ALC)</b>	48	19
<b>Factory Alignment (with ALC Reserve, without EQ)</b>		
Cable Loss, dB @ 1002MHz	23	—
Flat Loss, dB	21	19
Gain Slope, dB	–1.0 to 1.0	—
Flatness (@ Gain Slope), ±dB (Note 12)	±1.0	0.5
Return Loss, dB min., all entry ports	16	16
<b>Powering Requirements, max./typ. (Note 13)</b>		
AC Voltage, 60Hz		<b>With Active Return</b>
AC Power, Watts		@ 90V                      @ 60V
AC Current, mA		45.5/41                      45/40
DC Current, mA @ 24V ± 0.5V		670/630                      820/740
		1650/1475                      1650/1475
<b>Level Control</b>		
Range, dB @ 1002 MHz	+4/–5 dB	—
Accuracy (–40 to 60°C)	±0.5 dB	—
Pilot Level Range (Note 14)	+5/–3dB	—
Pilot Frequency Band (recommended) (Note 15)	499.25 MHz (single channel)	—

Specification Document Number 1502213 Rev D

### Notes:

- Spacing at highest frequency with SEQ-1G-xx installed. Reverse spacing included losses due to housing, diplex filters and MEQ-42-xx.
- The specifications are based on the amplifier configured (with two SPB-0s) as a 2-output bridger with distribution outputs on Ports 3 and 6. When using distribution plug-ins (SS-1000-2, SDC-1000-8, or SDC-1000-12), levels should be derated accordingly based on the accessory specifications.
- NTSC video channels occupying the appropriate frequency spectrum per specified number of channels.
- Recommended minimum forward input level at 1002MHz including loss due to equalizer.
- Recommended maximum reverse output level at 42MHz including loss due to equalizer.
- At specified operational tilt the maximum output level for 870MHz or 1 GHz loading is 56.5dBmV @ HF.
- Distortion performance is derated accordingly to account for the influence of the digitally compressed channels 6dB below equivalent video channels.
- Cross Modulation specifications number indicates typical cascade performance.
- Systems operating with digitally compressed channels or equivalent broadband noise from 550 to 1002MHz at levels 6dB below equivalent video channels will experience a composite distortion (CIN) appearing as noise in the 54 to 550MHz frequency spectrum.
- Systems operating with digitally compressed channels or equivalent broadband noise from 550-870 MHz at levels 6 dB below equivalent video channels will experience a composite distortion (CIN) appearing as noise in the 54-550 MHz frequency spectrum.
- Noise figure and C/N specifications are typical within specified passband.
- Forward bridger port gain and flatness (Ports 2, 3, and 5 only) is 0 ± 1.0dB as referenced to Port 6. Return bridger port gain and flatness (Ports 2, 3, and 5 only) is 0 ± 0.5 dB as referenced to Port 6.
- Powering requirements indicated are with the Model HEPS790-2.3 power supply 122027-05. See 333995-17 for additional information. For 60VAC Powering: AC Power consumption in Watts divided by a factor of 43 = Amps required. For 90VAC Powering: For £ 67VAC, 1.03 x (AC Power consumption in watts divided by voltage) = Amps required. For 67 - 90VAC, AC Power consumption in watts divided by 65 = Amps required.
- ALC pilot level range is based on a nominal pilot level of 34 dBmV for pilot frequencies £ 499.25 MHz or 31 dBmV for pilot frequencies > 499.25 MHz. ARRIS recommends that if the pilot level, from a design standpoint, is more than +2/-1 dBmV from nominal, the ALC PAD should be changed to optimize the ALC pilot level range. This should alleviate any possible ALC setup and/or operation issues due to typical system level variations caused by system components flatness characteristics. See the FM901e equipment manual (P/N 1502154) for correct selection of ALC PAD value to insure proper ALC setup and operation.

# C-COR® Flex Max901e 1 GHz Bridger Amplifiers

15. For ALC pilot frequencies of £ 499.25 MHz, the ALC pilot filter is a single channel device. This means that the adjacent channels will have no effect on the RF power level that the RF detector is measuring. For ALC pilot frequencies > 499.25 MHz, the ALC pilot filter is not a single channel device. This means that the adjacent QAM channels will have an effect on the RF power level that the RF detector is measuring. ARRIS recommends that the adjacent QAM channels be present on the system before the ALC system of the amplifier station is balanced. This will avoid station re-balance in the future when those QAM channels would be added to the system.
16. Specifications are typical for Flex Max901e Bridgers. Contact your ARRIS sales professional for Flex Max901e Trunk specifications.
17. Specifications for 870 MHz bridger configurations are available on request (*Specification document number 1502214*).  
Specifications subject to change without notice.

## Flex Max901e Bridger Amplifier Model Options

			<b>1</b>	<b>2</b>	<b>3</b>	<b>4</b>		<b>5</b>	<b>6</b>	<b>7</b>	<b>8</b>	<b>9</b>	<b>10</b>	<b>11</b>	<b>12</b>
<b>F</b>	<b>M</b>	<b>B</b>	<b>E</b>	<b>G</b>	<b>P</b>	<b>x</b>	<b>-</b>	<b>x</b>	<b>x</b>	<b>x</b>	<b>x</b>	<b>x</b>	<b>x</b>	<b>x</b>	<b>N</b>

<b>1 Series</b>	E Flex Max901e series	a
	a) 15A current passing capability.	

<b>2 Bandwidth</b>	G 1002MHz
--------------------	-----------

<b>3 Spacing</b>	P 43dB	a
	a) 23dB factory equalization.	

<b>4 Frequency Split</b>	J 42/54MHz
	N 65/85MHz
	Q 55/70MHz

<b>5-6 Level Control</b>	K0 427.25 MHz NTSC TV
	KB 439.25 MHz NTSC TV
	KC 451.25 MHz NTSC TV
	KL 423.25 MHz NTSC TV
	KN 471.25 MHz NTSC TV
	L0 499.25 MHz NTSC TV
	L4 495.25 MHz NTSC TV
	MB 645.00 MHz QAM
	RM 711.00 MHz QAM
	SD 609.00 MHz QAM

<b>7 Return</b>	6 18dB active gain	a
	7 18dB active gain with return switches	b
	a) Select "7" if future element management transponder is desired.	
	b) Operation of return switches requires a transponder.	

<b>8 Output Configuration</b>	E Two bridger outputs—user config. to 4 outputs with <b>-25 dB External</b> testpoints	a, e
	G Two bridger outputs—user config. to 4 outputs with <b>-20 dB Internal</b> testpoints	b, e
	N Two bridger outputs—user config. to 4 outputs with <b>-20 dB External</b> testpoints	c, e
	R Two bridger outputs—user config. to 4 outputs with <b>-25 dB Internal</b> testpoints	d, e
	a) Select "A", "F", or "L" in #10 block, <b>Housing</b> .	
	b) Select "A", "C", or "K" in #10 block, <b>Housing</b> .	
	c) Select "A", "F", or "L" in #10 block, <b>Housing</b> .	
	d) Select "A", "C", or "K" in #10 block, <b>Housing</b> .	
	e) Plug-in splitters and directional couplers must be ordered separately.	

<b>9 Powering</b>	1 None	a
	6 2.3A, 90V, 50/60Hz, H.E. transformerless	b
	a) Select "A" in #10 block, <b>Housing</b> . Required when ordering RF module only.	
	b) 40-90 V operating range; includes detachable power cable.	

<b>10 Housing</b>	A None	a
	C 6-port Flex Max, 1 GHz, <b>Internal</b> testpoints	b
	F 6-port Flex Max, 1 GHz, <b>External</b> testpoints	c
	K 6-port Flex Max, 1 GHz, four 90° access ports, <b>Internal</b> testpoints	b
	L 6-port Flex Max, 1 GHz, four 90° access ports, <b>External</b> testpoints	c
	a) Select "I" in #11 block, <b>Housing Finish</b> . Required when ordering RF module only.	
	b) Select "G" or "R" in #8 block, <b>Output Configuration</b> .	
	c) Select "E" or "N" in #8 block, <b>Output Configuration</b> . Forward testpoints only.	

<b>11 Housing Finish</b>	1 Standard (or N/A)	a
	4 Corrosion protected	
	a) Required when ordering RF module only.	

<b>12 Element Management</b>	N EMS capable	a, b
	a) Transponder sold separately: AM protocol (P/N 810-0354-01A) HMS protocol (P/N 810-0354-01H)	
	b) Must order mounting bracket kit (P/N 1501024)	

An HMS/AM protocol Value Max transponder is available to monitor and control the Flex Max901e Bridger Amplifier. Refer to the ARRIS HFC Product Accessories data sheet on our website for detailed ordering information and specifications on the complete set of plug-in accessories used in the Flex Max901e.

Contact your ARRIS sales professional for details and to discuss how our exciting new 1 GHz products can add value to your network.



The capabilities, system requirements and/or compatibility with third-party products described herein are subject to change without notice. ARRIS, the ARRIS logo, C3™, C4™, CableEdge®, Cadant®, C-COR®, CHP Max®, Cornerstone®, CXM™, D5™, Digicon®, Flex Max®, Keystone™, MONARCH®, n5™, nABLE™, NSM®, nVision™, PLEXIS®, Regal®, ServAssure™, TeleWire Supply™, Touchstone®, VoiceAssure™, and WorkAssure™ are all trademarks of ARRIS Group, Inc. Other trademarks and trade names may be used in this document to refer to either the entities claiming the marks and the names of their products. ARRIS disclaims proprietary interest in the marks and names of others. © Copyright 2008 ARRIS Group, Inc. All rights reserved. Reproduction in any manner whatsoever without the express written permission of ARRIS Group, Inc. is strictly forbidden. For more information, contact ARRIS.

FM901eB-D-0308





