



CORWave™ 1 GHz Forward Path Transmitter

C-COR® CHP Max5000

Converged Headend Platform

- 1-GHz technology
- Cost effective alternative to adding fiber infrastructure
- Rapidly deployable, robust, and scalable
- Multiplexes analog forward, reverse, and GbE based data services on limited fiber counts
- Add capacity to network at a cost effective price point
- Complements CHP Max® 1 GHz CWDM transmitters



The ARRIS C-COR® CHP Max5000 CORWave™ 1 GHz forward path transmitter is ideal for MSOs that need to support fast-growing residential and business services on a fiber-scarce HFC plant. The CORWave transmitter is an extension of field-proven CHP Max® CWDM transmitter series and delivers more wavelengths over longer link distances on existing fiber plant.

When deployed with the ARRIS C-COR® Opti Max4100 1 GHz 4 x 4 segmentable node, CORWave technology enables multiplexing of four forward wavelengths on one fiber with a link length of up to 25km. When deployed with any of the Opti Max segmentable nodes in 2 x 2 and 2 x 4 configurations, CORWave technology enables multiplexing of two forward wavelengths on one fiber with a link length of up to 30km. In addition, two bidirectional GigE links for business services can be delivered on the same fiber—in both configurations. Therefore, service groups can be up to four times smaller than they are today and carry business services without installing new fiber.

CHP Max5000 1 GHz forward path transmitters are dual-input and hot-swappable, with integrated management through the local Craft GUI and remote management via SNMP HMS-compliant interface for external connection to an element manager.

Rigorously tested and field-proven, ARRIS Multi-Wavelength Optical Network Solutions provide the flexibility to create the best wavelength plan—recovering fiber for revenue generating business services.

Features

- Delivers more wavelengths with more reach on your existing fiber
- Supports forward and return node segmentation and dedicated business service links without new fiber construction
- Multiplexes four forward wavelengths on a single fiber
- High isolation dual input transmitters help minimize complex combining networks and save precious space in the headend
- Service groups can be up to four times smaller than they are today utilizing the same fiber resources
- Management via CORView element management software provides real-time status of the optical platform
- 4 x 4 fully segmentable link when combined with CWDM node return path transmitters

Applications

The following diagrams depict the typical application for combining two or four CORWave wavelengths in the forward path. Then, they are multiplexed onto a single fiber with a maximum launch power of 11 dBm per wavelength—up to four. This facilitates immediate forward path segmentation and reduces the node service group size. Follow the implementation requirements listed in the table below the diagrams to ensure a successful implementation. Contact ARRIS for implementation details and solutions for other applications.

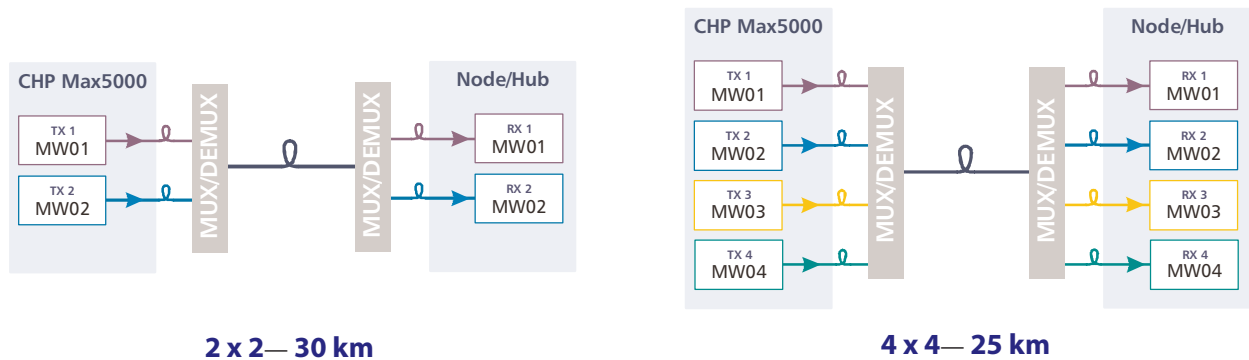

Implementation Requirements for Four-Wavelength Applications

Implementation Requirements	Four Wavelength Application
Unique Requirements	
Recommended wavelengths (note 1)	MW01-1291, MW02-1293, MW03-1295, MW04-1290
Maximum launch power/wavelength	11 dBm (4 wavelengths)
Common Requirements	
Analog broadcast content	Must use identical analog content
Digital broadcast content	Can use different, digitally modulated narrowcast content
Analog RF input level	13.5 to 15 dBmV/channel
Digital RF input level	7.5 to 9 dBmV/channel
Maximum RF input cable length difference to transmitters	100 feet

Notes

1. ARRIS recommends to deploy MW01-1291 as the first wavelength.

Transmitter Specifications

Optical	
Optical Wavelength	MW01-1291, MW02-1293, MW03-1295, MW04-1290
Optical Output Power	4, 6, 8, 10, 13 dBm (Refer to CNR vs. Link Budget Tables)
RF	
Bandwidth	
Operational Range	54 to 1002 MHz
Analog Channel Range	54 to 550 MHz
Digital Channel Range	550 to 1002 MHz
Response Flatness, P-V, typ./max.	1.0/2.0 dB
Input Return Loss	16 dB
Port-to-Port Isolation	≥60 dB, 54 to 870 MHz, ≥50 dB, 870 to 1002 MHz
Port-to-Port Gain Variation, typ./max.	±0.5 dB/±1.0 dB
Powering	
Power Consumption, max.	17.4 W
Performance	
Channel Plan	78 NTSC channels and up to 75 256-QAM channels
Input RF Power	
Analog Channels (Notes 1 and 2)	15.0 dBmV/ch
Digital QAM Channels	9.0 dBmV/ch
Composite Second Order, typ. (Notes 1 and 3)	-63 dBc
Composite Triple Beat, typ. (Note 1)	-70 dBc
Mechanical	
Optical Connector	SC/APC
RF Connector	F-type
RF Input Test Point (Note 4)	-20 ± 1.0 dB
Dimensions (W x H x D) (Note 5)	1.25 x 3.4 x 18.5 in. (3.2 x 8.7 x 47.0 cm)
Weight	2.75 lbs (1.24 kg)
Environmental	
Operational Temperature (Note 6)	32 to 122°F (0 to 50°C)
Storage Temperature	-40 to 158°F (-40 to 70 °C)
Humidity, noncondensing, max.	85%

Notes:

- Distortions are measured using only CW analog carriers per SCTE recommendation by standard RF test methods. Performance shown represents typical performance for ≥85% of production units tested over typical Corning SMF-28 fiber (or equivalent). For minimum CSO and CTB, subtract 2dB from typical. CSO performance is for the transmitter only. CSO specifications for CORWave transmitter is obtained over specified fiber links. The typical system CSO is -60 dBc assuming an 11 dBm launch per wavelength for a four-wavelength system.
- OMI is 3.9% at 78 NTSC channel loading.
- CSO performance for NTSC channels is for the in-band (high-side) beats.
- Relative to main port with 0 dB pad and 0 dB EQ.
- Includes handles and connectors.
- Temperature measured at transmitter module's air inlet.

Specifications subject to change without notice

C-COR® CHP Max5000 CORWave 1 GHz Forward Path Transmitter

CNR vs. Link Budget: CHP-MWxx-xxxx-xx-S 1 GHz CORWave Transmitters

	-04	-06	-08	-10	-13
Output Power (dBm)	4.0	6.0	8.0	10.0	13.0
Fiber Length (km)	7.0	13.0	15.0	15.0	25.0
Optical Loss Budget (dB)	CNR (dB) for part fiber/part passive link (typical)				
3	54.5	—	—	—	—
4	54.0	—	—	—	—
5	53.4	53.9	—	—	—
6	52.7	53.3	—	—	—
7	51.8	52.7	53.8	—	—
8	—	52.0	53.2	—	—
9	—	51.1	52.6	53.8	—
10	—	—	51.9	53.2	—
11	—	—	51.0	52.6	—
12	—	—	—	51.9	53.4
13	—	—	—	51.0	52.8
14	—	—	—	—	52.2
15	—	—	—	—	51.5
16	—	—	—	—	50.6

Notes:

- Optical output power specified before transmitter's bulkhead.
- CNR is measured using only CW analog carriers per SCTE test procedures. Performance shown is ambient. Subtract 0.5 dB for performance over full temp. range.
- Specifications measured using typical receiver with 0.85 mA/mW, 7 pA/Hz^{0.5} performance.
- Performance valid for 78 NTSC modulated channels at 15 dBmV/channel and 450MHz of QAM loading at 6 dB below equivalent video channels.
- Multiple forward wavelengths on a single fiber requires specific application considerations, please contact ARRIS for system design guidance.

Specifications subject to change without notice

Ordering Information

				1	2	3	4	5	6	7	8	9		10	11		12
C	H	P	-	M	W	x	x	-	x	x	x	x	-	x	x	-	S

1-9	CWDM Optical Wavelength
MW01-1291	MultiWave #01 - 1291 nm (first wavelength to be deployed)
MW02-1293	MultiWave #02 - 1293 nm
MW03-1295	MultiWave #03 - 1295 nm
MW04-1290	MultiWave #04 - 1290 nm

10-11	Optical Output Level
04	Fixed optical output power of 4 dBm
06	Fixed optical output power of 6 dBm
08	Fixed optical output power of 8 dBm
10	Fixed optical output power of 10 dBm
13	Fixed optical output power of 13 dBm

12	Connector Type
S	SC/APC



The capabilities, system requirements and/or compatibility with third-party products described herein are subject to change without notice. ARRIS, the ARRIS logo, C3™, C4™, CableEdge®, Cadant®, C-COR®, CHP Max®, Cornerstone®, CXM™, D5™, Digicon®, Flex Max®, Keystone™, MONARCH®, n5™, nABLE™, NSM®, nVision®, PLEXIS®, Regal®, ServAssure™, TeleWire Supply®, Touchstone®, VoiceAssure™, and WorkAssure™ are all trademarks of ARRIS Group, Inc. Other trademarks and trade names may be used in this document to refer to either the entities claiming the marks and the names of their products. ARRIS disclaims proprietary interest in the marks and names of others. © Copyright 2008 ARRIS Group, Inc. All rights reserved. Reproduction in any manner whatsoever without the express written permission of ARRIS Group, Inc. is strictly forbidden. For more information, contact ARRIS.

CORWAVE-D-1008



www.arrisi.com



CORWave™ Optical Passives

LGX Style Headend
Opti Max4100 node
Tyco splice enclosure



ARRIS offers a complete line of CORWave™ optical multiplexers and demultiplexers:

- LGX style optical passive for the headend—standard or compact
- For the Opti Max4100 node fiber tray
- For the Tyco splice enclosure

These packages support 4 x 4, 2 x 4, and 2 x 2 network segmentation.

Service providers can initially deploy their first CHP Max5000 CORWave 1GHz Forward Path Transmitter wavelength MW01-1291 and the Opti Max4100 1GHz fully segmentable node in a 1 x 4 configuration. As the need for both expanded bandwidth and smaller service group size increase, service providers can easily upgrade the network with a drop-in 4 x 4 fully segmented link with four forward CORWave transmitters and four return CWDM transmitters. Combining optical links with ARRIS C-COR® CHP Max5000 CWDM or CORWave forward path transmitters, a CORWave LGX style, and a CORWave Opti Max4100 Optical Passive, the same Opti Max4100 node can be operated with a single fiber—depending on link length—enabling service providers to use remaining fibers for revenue-generating business services.

The ARRIS C-COR CORWave OM4100 Optical Passives are a technician-friendly solution inside the node to facilitate end-to-end, multi-wavelength networks. These optical passives, which fit into the existing Opti Max4100 fiber management tray thereby eliminate the need for custom mounting brackets, enable simultaneous transmission of optical signals at multiple wavelengths over as few as one fiber.



CORWave™ Optical Passives LGX Style Headend Opti Max4100 node Tyco splice enclosure

Features

- Facilitates quick segmentation without costly fiber construction
- Easy installation without the need to open weatherproof optical splice enclosures, nor the need for specialized equipment and complex fiber routings in the field
- Superior isolation and low insertion loss over the entire operating temperature range helps assure long-term network performance
- Facilitates pay-as-you-grow upgrades while installing additional receivers and transmitters
- Upgrade ports available to allow future network expansion without the interruption of existing services
- User-friendly with ergonomic design simplifies craftsmen training an installation times

Optical Passives Specifications

Operating Wavelength Range	1260 to 1380 nm and 1400 to 1620 nm
Channel Options	CORWave 4x4: MW01-1291, MW02-1293, MW03-1295, MW04-1290 CORWave 2x4: MW01-1291, MW02-1293 CWDM return paths: 1471, 1491, 1591, 1611 nm
Channel Wavelength Range	λ .CORWave ± 0.2 nm λ .CWDM ± 7.0 nm
Upgrade Port Wavelength Range	At non-selected CWDM and CORWave channels within the operating range
CORWave Channel Insertion Loss (per end)	2.0 dB typical (2.5 dB maximum) for 4x4 configurations 1.5 dB typical (2.0 dB maximum) for 2x4 configurations
CWDM Channel Insertion Loss (per end)	2.0 dB typical (2.5 dB maximum) for 4x4 configurations 2.0 dB typical (2.5 dB maximum) for 2x4 configurations
Upgrade Port Insertion Loss	3.0 dB
Upgrade Port Isolation	>15 dB
Insertion Loss Change Over Operating Temperature - All Ports	< ± 0.3 dB
Optical Return Loss	>45 dB
Operating Temperature	-40 to +85 C
Optical Power	300 mW

Optical Passives Part Numbers

Part Number	Description
OMW08L5FC5T1	CORWave Passive 4x4, optical mux, LGX style, SC/APC, upgrade port; FWD path: MW01-1291, MW02-1293, MW03-1295, MW04-1290; REV Path: 1471 nm, 1491 nm, 1591 nm, 1611 nm
ODW08P5FC5T1K03	CORWave Passive 4x4, optical demux, OM4100 node fiber tray, SC/APC, upgrade port; FWD path: MW01-1291, MW02-1293, MW03-1295, MW04-1290; REV Path: 1471 nm, 1491 nm, 1591 nm, 1611 nm
ODW08T5FC5T1B00	CORWave Passive 4x4, optical demux, Tyco splice encoder, SC/APC, upgrade port; FWD path: MW01-1291, MW02-1293, MW03-1295, MW04-1290; REV Path: 1471 nm, 1491 nm, 1591 nm, 1611 nm
OMW06L5FD5T1	CORWave Passive 2x4, optical mux, LGX style, SC/APC, upgrade port; FWD path: MW01-1291, MW02-1293; REV Path: 1471 nm, 1491 nm, 1591 nm, 1611 nm
ODW06P5FD5T1K03	CORWave Passive 2x4, optical demux, OM4100 node fiber tray, SC/APC, upgrade port; FWD path: MW01-1291, MW02-1293; REV Path: 1471 nm, 1491 nm, 1591 nm, 1611 nm
ODW06T5FD5T1B00	CORWave Passive 2x4, optical demux, Tyco splice encoder, SC/APC, upgrade port; FWD path: MW01-1291, MW02-1293; REV Path: 1471 nm, 1491 nm, 1591 nm, 1611 nm



The capabilities, system requirements and/or compatibility with third-party products described herein are subject to change without notice. ARRIS, the ARRIS logo, C3™, C4™, CableEdge™, Cadant™, C-COR™, CHP Max™, Cornerstone™, CXM™, D5™, Digicon™, Flex Max™, Keystone™, MONARCH™, n5™, nABLE™, NSM™, nVision™, PLEXIS™, Regal™, ServAssure™, TeleWire Supply™, Touchstone™, VoiceAssure™, and WorkAssure™ are all trademarks of ARRIS Group, Inc. Other trademarks and trade names may be used in this document to refer to either the entities claiming the marks and the names of their products. ARRIS disclaims proprietary interest in the marks and names of others. © Copyright 2008 ARRIS Group, Inc. All rights reserved. Reproduction in any manner whatsoever without the express written permission of ARRIS Group, Inc. is strictly forbidden. For more information, contact ARRIS.

CORWAVEOPTPASS-D-1008B

