



## Dual-Input Return Path Transmitters

### CHP-RTX

#### C-COR® CHP Max5000

- 1310nm short-haul and 1550nm ITU long-haul versions
- High density allows 10 modules per chassis and 200 per 40RU rack
- Simplified installation and management with graphical user interface
- Universal management through Craft interface and SNMP with HMS

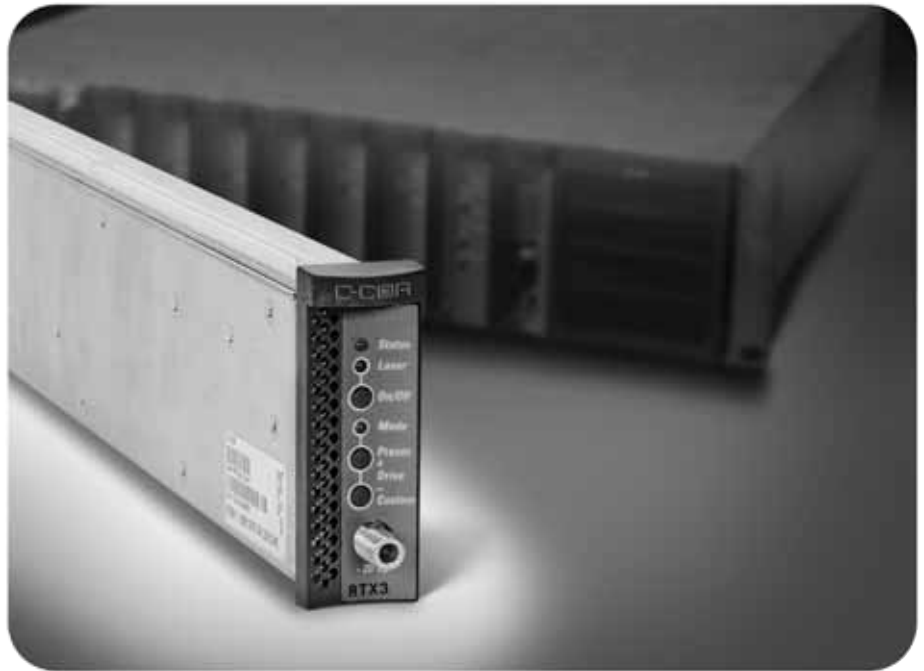

ARRIS C-COR CHP Max5000 Dual-Input Return Transmitters are an integral part of return path system applications. Advanced two-way services—such as high speed Internet access and telephony—require superior return path delivery capacity and performance. C-COR's CHP Max5000 converged headend platform can help you meet these demands.

The 2RU CHP Max5000 chassis can accommodate up to 10 dual-input return transmitters (up to 200 transmitters in one standard 6-foot rack) to relieve the pressure on precious headend space as you expand offering of advanced two-way services.

CHP Max5000 Dual-Input Return Transmitters are available in two versions—1310nm and 1550nm—both of which transmit in the 5 to 200MHz spectrum and offer 60dB of isolation between input ports. The 1310nm version is ideal for links up to 50km, while the 1550nm version is designed for longer links up to 100km and for fiber challenged applications. Further distances can be achieved when using the CHP 1550 ITU Return Transmitter with the CHP Max5000 EDFA series modules, which simplifies applications by providing low noise, integrated element management capability, reduced rack space, and power requirements providing both CapEx and OpEx savings.

CHP Max5000 Dual-Input Return Path Transmitters offer hot-swapping and integrated monitoring and configuration control through a Craft graphical user interface with local or remote access. Remote management is accessible through the SNMP HMS-compliant interface for external connection to an element manager. Energy efficient internal components and effective thermal design keep lasers cool to ensure for effective, reliable performance.

## Features

- High density return path solution with reduced heating, cooling, and power costs
- High 60dB isolation between input ports
- Front-panel RF test point for convenient monitoring
- Local or remote monitoring and configuration control using the Craft GUI
- Downloadable firmware upgrades

## CHP Max5000 Headend Platform Diagram

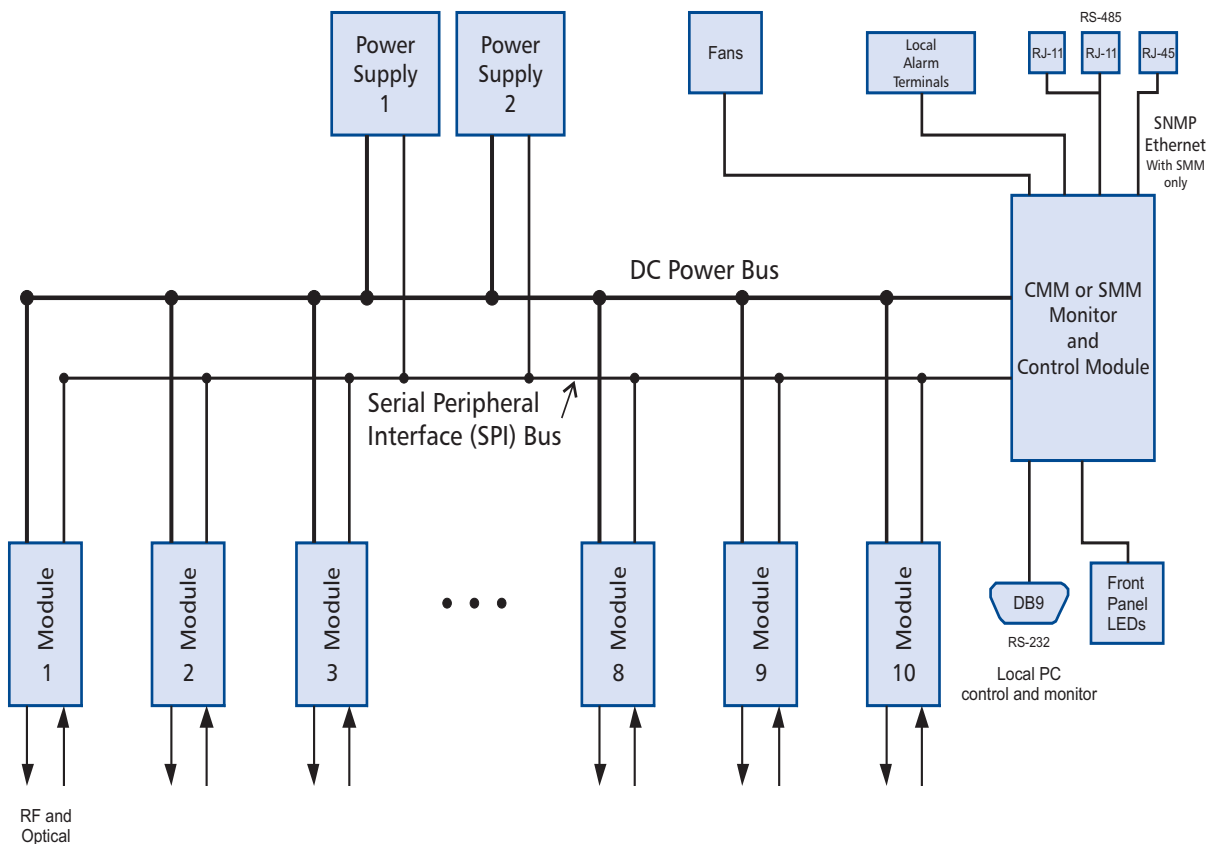

## Specifications

	CHP-RTX3-10-S Series	CHP-RTX5-10-S-xx Series
<b>Optical</b>		
Wavelength	1310 ± 10nm	1529 to 1561 nm
Wavelength Drift, max.	0.15nm	0.15 nm
Output Power	10 ± 0.25dBm	10 ± 0.25dBm
Laser Bias Current	5 to 120mA	5 to 120mA
Laser Current Limit	150mA	150mA
Laser Internal Temperature	15 to 35°C (59 to 95°F)	15 to 35°C (59 to 95°F)

## Specifications (cont'd)

<b>RF</b>		
Bandwidth	5 to 200MHz	5 to 200MHz
Input Impedance	75Ω	75Ω
Frequency Flatness, 25°C (77°F), typ.	± 0.5dB	± 0.5dB
Input Return Loss	16dB	16dB
RF Input Test Point, 25°C (77°F) (Note 1)	-20 ± 0.75dB	-20 ± 0.75dB
Port-to-Port Isolation	>60dB	>60dB
Unit-to-Unit Isolation	>65dB	>65dB
Port-to-Port Gain Variation, max.	± 1.0dB	± 1.0dB
<b>Powering</b>		
Power Consumption, max.	17.4W	17.4W
<b>Performance</b>		
Total Input RF Power, nominal	33dBmV	33dBmV
Noise-Power Ratio (NPR)/Dynamic Range	35/12dB (50km fiber with -12dBm into RX)	35/12dB (75 km fiber with -12dBm into RX)
PIN Attenuation Range, min./typ.	8/9dB	8/9dB
<b>Mechanical</b>		
Optical Connector	SC/APC	SC/APC
RF Connector	F-type	F-type
Dimensions (W x H x D) (Note 2)	1.25 x 3.4 x 18.5in. (3.2 x 8.7 x 47.0cm)	1.25 x 3.4 x 18.5in. (3.2 x 8.7 x 47.0cm)
Weight	2.75lbs (1.24kg)	2.75lbs (1.24kg)
<b>Environmental</b>		
Operational Temperature (Note 3)	0 to 50°C (32 to 122°F)	0 to 50°C (32 to 122°F)
Storage Temperature	-40 to 70°C (-40 to 158°F)	-40 to 70°C (-40 to 158°F)
Humidity, max. noncondensing	85%	85%

Notes:

1. Relative to main port with 0dB PAD.
2. Includes handles and connectors.
3. Temperature measured at transmitter's air inlet.

Specifications subject to change without notice

# C-COR™ CHP Max5000 Dual-Input Return Path Transmitters

## Ordering Information

				<b>1</b>	<b>2</b>	<b>3</b>	<b>4</b>		<b>5</b>	<b>6</b>		<b>7</b>		<b>8</b>	<b>9</b>
<b>C</b>	<b>H</b>	<b>P</b>	<b>-</b>	<b>R</b>	<b>T</b>	<b>X</b>	<b>x</b>	<b>-</b>	<b>1</b>	<b>0</b>	<b>-</b>	<b>S</b>	<b>-</b>	<b>x</b>	<b>x</b>

1-4 Wavelength		
RTX3	1310nm	a
RTX5	1550nm ITU	
a) Leave blocks #8-9, ITU Channel, blank if ordering a 1310nm transmitter		

5-6 Output Power	
10	10dBm

7 Connector Type	
S	SC/APC

8-9 ITU Channel		
Blank	No ITU channel (1310nm)	a
21	ITU channel 21	
23	ITU channel 23	
25	ITU channel 25	
27	ITU channel 27	
29	ITU channel 29	
31	ITU channel 31	
33	ITU channel 33	
35	ITU channel 35	
37	ITU channel 37	
39	ITU channel 39	
41	ITU channel 41	
43	ITU channel 43	
45	ITU channel 45	
47	ITU channel 47	
49	ITU channel 49	
51	ITU channel 51	
a) Must select "RTX3" in #1-4 block, Wavelength.		
Contact ARRIS for other ITU wavelength choices		

See the CHP Max5000 Converged Headend Platform data sheet for additional ordering information.

The capabilities, system requirements and/or compatibility with third-party products described herein are subject to change without notice. ARRIS, the ARRIS logo, Auspice®, C3™, C4®, Cadant®, C-COR®, CHP Max®, Cornerstone®, CXM™, DS™, Digicon®, Flex Max®, Keystone™, MONARCH®, n5™, nABLE™, NSM™, nVision®, OpsLogic®, OpsLogic Service Visibility Portal™, PLEXIS®, PowerSense™, Regal®, ServAssure™, Service Visibility Portal™, TeleWire Supply®, TLX®, Touchstone®, VoiceAssure™, VSM™, and WorkAssure™ are all trademarks of ARRIS Group, Inc. Other trademarks and trade names may be used in this document to refer to either the entities claiming the marks and the names of their products. ARRIS disclaims proprietary interest in the marks and names of others. © Copyright 2009 ARRIS Group, Inc. All rights reserved. Reproduction in any manner whatsoever without the express written permission of ARRIS Group, Inc. is strictly forbidden. For more information, contact ARRIS.